

# A decision tree approach for integrating small business assistance schemes

Zealelem T. Temtime, S.V. Chinyoka and J.P.W. Shunda  
*University of Botswana, Gaborone, Botswana*

**Keywords** *Developing countries, Economics, Small enterprises, Government policy, Botswana, Decision trees*

**Abstract** *There is a general consensus among public policy makers, academics and researchers that entrepreneurship is a vital route to economic advancement for both developed and developing economies. As a result, a host of small business assistance programs are conducted by public, private and nonprofit organizations. Although the need for integrating these programs has always been a high priority on the national agenda for public policy and research in entrepreneurship, their implementation particularly in developing economies is characterized by fragmentation and lack of coordination. Small business assistance will be meaningful if they are designed in a holistic and systematic way and implemented with a view to achieve long term sustainable development. This paper offers a conceptual framework for designing an integrated model of small business assistance. The paper identifies the major characteristics of small firms and potential small business assistance programs, and presents a decision tree model that matches the characteristics of firms with appropriate assistance program(s). A case study of small business assistance programs in the Republic of Botswana was conducted to provide an empirical evidence of the need for an integrated design or model. Finally, conclusions, discussions and the implications of the model for policy makers, practitioners and further research are presented.*

## Introduction

Since its independence in 1966, Botswana has achieved a remarkable growth in economy, socio-political stability, and education. Its current political administration, which is one of the leading democratic systems in Africa, is based on equity in the distribution of resource and services. Although the discovery of mineral wealth (i.e. diamond) has propelled Botswana into the middle-income category, the country still faces the problem of economic diversification, employment creation, income distribution and poverty alleviation. The country's economy is highly dependent on the mining and beef sector(s) for its income and on foreign markets for the import of basic goods and services (Government of Botswana, 1997).

Although the Government of Botswana has designed various diversification programmes and policies, the main focus has been on the promotion of the development of small enterprises (Government of Botswana, 1998). The most common argument in favor of small businesses is that they create substantial job opportunities as they use relatively labor-intensive technologies. Small firms employ more people per unit of investment as compared to large firms. Thus, a given amount of money will create more jobs if it is spread over a large number of small firms than if it is focused on few large companies (Asri and Baker, 2000).

The major and immediate challenge for Botswana is providing employment for low-skill labor. The declining job opportunities in the South African mines for

Batswana, the prevalence of low-skill and unskilled labor force in the economy, and the tendency of the government to reduce its role as primary employer made the promotion of small firms a primary source of employment creation. Small businesses contribute not only to income generation but also income distribution. Large firms normally tend to produce an elite number of high wage income earners whereas small firms produce a significantly large number of relatively low-income earners. The development of small firms would therefore help spread income to more people. Since the majority of Batswana (over 65 percent) are living in rural areas, the promotion of the development of small businesses should continue to be a policy priority to narrow the gap between urban and rural development and to monitor social inequities and rural migration.

Small firms also promote the culture of saving and investing in society. The money invested in small businesses would probably have been allocated to consumption expenditure if small firms have not been established or sought for it. This nature of propensity to save and invest, induced by the development of small firms, can directly contribute to the overall savings ratio of the population of Botswana. Enhancing the poverty alleviation potential of small firms through financial, regulatory and managerial assistances will eventually reduce dependency on foreign markets. This will not only save foreign exchange but also reduce the impact, which fluctuations of foreign exchange receipts will have domestically. The promotion of the development of small- to medium-sized enterprises (SMEs) will, therefore, have a long run effect of economic independence, and sustained sovereignty and autonomous development.

Government agencies and small business support providers have long been concerned with the designing and implementation of effective small business assistance schemes and interest in this issue seems to be growing. Several writings and presentations in international conferences continue to exhort the virtues of one assistance scheme or another for solving small business problems. It is obvious that, there is no one best comprehensive assistance scheme for all problems of small businesses. Each assistance scheme-be it financial or advisory-has varying degrees of relevance to different types of small business problems. But, what has been lacking is a conceptual framework or model for determining when these various schemes are most appropriate and effective. In order to develop a useful model for designing small business assistance schemes, a way of classifying assistance schemes and a way of defining and categorizing the nature of small business problems, and a mechanism for measuring the effectiveness of these schemes are needed. Moreover, a technique or algorithm is necessary in order to link the input variables with the outputs of the model (Theodore, 1972).

This paper presents a decision tree model for designing small business assistance schemes. The model is believed to be valuable as it systematically brings into focus critical problems and other organizational considerations. The paper is organized under four major headings. First, we present five basic input variables that are used in the selection of appropriate assistance schemes, which are later translated into a decision tree format that provides a step-by-step approach to matching assistance schemes and problems. Second, we present a typology for the classification of small business assistance schemes. Third, we developed a decision tree model by matching basic input variables with selected sources of assistance. Finally, we present a case study of small business assistance programmes in Botswana in order to show evidence of need for the proposed model.



### Characteristics of small firms

Any attempt to address small business problems, which are often diverse and complex, must be based on the study of their demographic characteristics. Different firms need different types of assistance such as financial, material, technical, advisory, educational, etc because firms may differ in size, form of ownership, industry type, stages of development, sources of capital, leadership and so forth. Thus, the designing of effective small business support program requires consideration of some critical organizational and managerial factors that have serious repercussions on the performance of small firms (Randolph and Barry, 1979).

The authors have identified, mainly from the literature, 16 variables affecting the types of assistance needed for the firm under consideration. These variables were reviewed, along with the classification of potential assistance schemes using a panel consensus process. The discussion on the 16 pre-selected variables has resulted in several modifications and reduced the variables to only five: business plan or idea, previous experience, legal form, capital structure, and industry type. These variables are believed to assist in the determination of assistance schemes that are appropriate to the characteristics of the small firm. They constitute an important set of questions, which should be dealt with, and considered in the selection of suitable assistance schemes. Although there are several assistance schemes in an economy, the authors used a two-dimensional classification of assistance schemes-strategic-operational continuum, and advisory-material continuum. The authors then discussed on the need for a decision tree model, which appear to provide a generally useful framework for linking and analyzing the characteristics of firms and the available and accessible assistance schemes. The following sections discuss the five basic input variables (questions) and the classification of assistance schemes. The small business assistance provider must understand and effectively answer the five basic questions before recommending any assistance scheme.

#### *Does the client have a clear business plan or idea?*

The question "Does the client have a written business plan?" is designed to study whether the small business has well established goals and objectives (or business ideas) to achieve. While the question calls for a "yes" or "no" response, it should be noted that the issue "plan or idea" involves a great deal of latitude in that almost all entrepreneurs have some "good ideas" at least in their minds. The real issue is how practical or realistic their plan or idea is. Some prospective entrepreneurs/clients present their interest as business plan or idea or hire consultants to produce a formal plan, which they do not understand properly. Thus, the designers should note that all "yes" answers do not necessarily indicate the existence of properly worked out business plans. It is therefore important to use additional information to determine the practicality of the plan or the idea in that given market or business environment. A "no" answer shows that the assessor, following careful analysis of the contents of the business plan or idea, has reached the conclusion that the firm does not have a sound plan or idea that seems realistic and achievable even after some modifications, or that it would not be effective or successful in the long run. However, this does not mean that firms without sound business plan or idea will not get any assistance. These firms can be effectively assisted to develop entrepreneurial orientation and the fundamental skills of business management.

*Does the owner/manager have previous business experience?*

The question "Does the firm have previous business experience?" does not imply that previous experience in running one's own business is a must to start a new business or to get assistance. The firm or owner/manager does not necessarily need to have managerial or ownership history or experience. Rather, the issue is exposure to business practices or general understanding of the what and how of the proposed business. Once again, the support provider or assessor must gather additional information regarding the managerial and operational capabilities of owners/managers and exercise professional judgment in determining their relevance for future success.

For example, even though the owner/manager has no adequate business experience, the assessor or support provider may make the determination that, given the relatively simple nature of the proposed business, low risk involved in running the business, availability of good market or demand for the product or services, and the capacity of the client to "catch on quickly", the answer to this question should be "yes". Since the objective is to minimize the negative impacts of lack of previous experience on the performance of the firm, the assessor must again concentrate not on the "yes" or "no" answers, but on the challenges that lack of previous experience will bring about on the start-up firm. This analysis will eventually indicate the type of assistance scheme appropriate for owner/managers with or without previous business exposure.

*Is the firm organized as a sole proprietorship?*

The question "is the proposed business organized as a sole proprietorship?" implies that the composition of top management and ownership structure can significantly affect the type, nature and effectiveness of the assistance schemes. It is generally assumed that small firms fail due to "poor management" (Argenti, 1976), which is largely affected by the legal form of organization and ownership structure. Limited and unlimited liability firms have different managerial composition. Form of organization affects the competency and adequacy of management as most corporations, as opposed to sole proprietorship and partnership firms, are managed by employed professional manager rather than owners or part-owner managers. The problems of corporations are, for example, more complicated than partnership or sole proprietorship firms. However, this does not mean that shared ownership is always problematic. The assessor's concern should be to evaluate the impact of legal form of organization on the managerial decision making process in the firm as this is pivotal to the survival and growth of the proposed firm. The assessor should examine the compatibility of the proposed business and legal obligations of the owner/manager.

*Is this an equity-financed firm?*

The forth-critical input factor is the question of source of capital for the proposed firm, which is related to complexity of the business setting in terms of capital. Although theory of capital structure shows that debt financing and equity financing will be advantageous in different market scenarios and at different stages of growth of the firm, the important point is not only to see the financial commitment made by the client but also to see the magnitude of the debt and its impact on the performance of the firm both in the short and long run (Modigliani and Miller, 1958). It should be noted that although it is difficult to determine the appropriate capital structure (equity-debt ratio), the assessor's concern should be the impact of the sources of capital on the future



performance of the firm. If the proportion of equity to debt is very high, the effect of interest and loan repayments on the working capital of the firm will be relatively small and much assistance schemes could be designed to address functional, managerial, and marketing related problems. However, if the firm is largely financed by debt, the assistance scheme could be directed toward working capital management and loan settlement in a way that does not hamper business operations (Barton and Mathews, 1989; Cowan, 1990).

#### *Is the firm operating in a service industry?*

The question “Is the firm operating in a service industry?” is related to the evaluation of the complexity of the business setting in terms of industry type. Firms operating under different industries might have varying degrees of organizational and environmental complexity. Thus, all firms do not need similar assistance packages. The objective of the assessor is not just to know the type and nature of the proposed business. It is important to know the forces of profitability in that particular industry (Argenti, 1976). The intensity of competition, concentration and power of suppliers and customers, as well as availability of substitute products in the market in the industry must be analyzed. Although it seems generally more complex to start a manufacturing firm than a service firm in terms of investment and facilities (Olen, 1989), there are also some situations where starting a service business (e.g. online shopping) will be more challenging than a manufacturing business (manufacturing garden furnitures). Sometimes it won't even be easy to label a firm as either service or manufacturing.

#### **A typology of design options**

What sources of small business assistance are available in the economy for use by small firms with “yes” or “no” response to the five basic input variables? Small business problems are numerous and complex. Since it is difficult to determine the appropriate assistance scheme for each specific problem, the logical approach to the classification of assistance schemes is to use continuums instead of a fixed classification. The authors have developed two major dimensions dealing with the type and nature of assistance schemes. Four assistant schemes (I-IV) are designed and incorporated into the model under the two dimensions that need to be considered in understanding the type and nature of the schemes. The first dimension is the nature of small business assistance schemes as measured on a continuum from operational (short-term) to strategic (long-term) perspective. This horizontal axis shows whether the scheme is designed to solve immediate short-term problems or to achieve long-term competitiveness through continued assistance. The schemes range from providing simple training (cell II) or micro financing services (cell I) to the development of strategic awareness (cell III) and large scale growth financing (cell IV).

As shown in Figure 1, the second dimension is related to the type of the assistance scheme, as measured on a continuum from advisory services to resource allocation and mobilization. This vertical axis shows whether the most crucial problem is the provision of information/advisory services or material/resources. The schemes range from simple consultation services on functional (cell II) or strategic problems (cell III) to the provision of material/financial assistance either to achieve operational efficiency (cell I) or long term sustainability (cell IV).

**Figure 1.**  
Classification of assistance  
schemes

---

A D V I S O R Y	<b>II. BUSINESS GUIDANCE</b>	<b>III. COMPETITIVE AWARENESS</b>
	<ul style="list-style-type: none"> <li>• Basic Skills development</li> <li>• Business planning</li> <li>• Market Identification</li> <li>• Employee relations</li> <li>• Basic skills development</li> </ul>	<ul style="list-style-type: none"> <li>• Visioning and achievement</li> <li>• Competitive benchmarking</li> <li>• Diversification/growth mgt</li> <li>• Strategic management/networking</li> <li>• Sustainable growth management</li> </ul>
M A T E R I A L	<b>I. CAPACITY BUILDING</b>	<b>IV. TOTAL EMPOWERMENT</b>
	<ul style="list-style-type: none"> <li>• Short-term loan/credits</li> <li>• Facilities/Equipments</li> <li>• Infrastructure/Premise</li> <li>• Training subsidy</li> </ul>	<ul style="list-style-type: none"> <li>• Long term loan/rent/grants</li> <li>• Expansion facilities/import-export</li> <li>• Reservation/External linkages</li> <li>• New business incubation package</li> </ul>
	<b>OPERATIONAL</b>	<b>STRATEGIC</b>

Using the two dimensions, the various assistance schemes available in the economy can be classified as one of four cells: (I) capacity building (II); business guidance (III); competitive awareness and (IV); total empowerment. Each of these cells (assistance schemes) is briefly discussed in relation to the five basic input variables.

#### *Capacity building*

Cell I focuses on the need to assist small businesses by providing material and financial resources. Several small firms fail because of inadequate capital or investment. Small firms with sound business ideas or plans can approach support providers for short-term credits and loans. This assistance scheme is particularly important for firms with strong financial and material need for expansion or start-up. This scheme holds that small businesses with viable business ideas and previous experience can be provided material and financial assistance to overcome primarily their operational (short-term) problems. This scheme is chosen ideally whenever the short-term survival of the firm depends more on resource allocation and less on advisory services (Temtime *et al.*, 2002a).

#### *Business guidance*

Cell II deals with an assistance scheme that focuses on the provision of information in the form of education, training, and orientation as well as specialized technical assistance in such areas as marketing, inventory control, and hiring and selection. Like cell I, this scheme also focuses on solving short-term operational problems through expert guidance services. Examples of this scheme include basic training in accounting, production scheduling, and quality control. Client firms may still have viable business plans but lack basic management skills to effectively run the firm's day-to-day business. This scheme is widely used by training programs of international organizations such as UNDP and ILO in their attempt to develop basic business management skills in developing economies (Daniels and Fisseha, 1992; Temtime *et al.*, 2002a).

### *Competitive awareness*

Cell III is similar with cell II but focuses on the promotion of long-term competitiveness through education and training rather than improving short-term operational efficiency. Although some firms do not have immediate operational problems, they are not growth oriented. They lack vision for expansion and growth. Small businesses can be provided advanced venture management techniques in the form of executive development programmes. Firms will be assisted in making competitive benchmarking, industry analysis, value chain investigation, investment analysis, and diversification strategies (Temtime *et al.*, 2002b).

### *Total empowerment*

Cell IV also focuses on the long-term sustainability of the small firm, but provides the tangible means like expanded loan and credits, growth financing sources, import and export benefits, and expansion facilities rather than education and training. Generally, the assistance scheme targets the development of long-term competitiveness and export-oriented development. The scheme is based on the assumption that small firms at different stages of development have different problems. Total empowerment is a comprehensive assistance scheme designed to accelerate the growth and success of entrepreneurial companies through an array of business support resources and services (Temtime *et al.*, 2002a). The survival of some firms is questionable unless they are provided with comprehensive assistance. They need to be nurtured for some time. Companies with somehow good business ideas, reasonable experience, small equity capital may be selected as tenants for incubation, the total empowerment option is costly and often chosen when the prospective business contributes more significantly to the national economy than any other area of investment, and when there are some indicators for the prospective firm to be successful in the of future (Williams, 1993).

### **A decision tree approach**

The preceding sections have identified five determinants of small business assistance and four alternative sources of assistance. The possible responses to the five basic input variables were matched with the selected assistance sources to construct a model in the form of decision tree (Figure 2). The purpose of this model is to assist public policy makers and small business support providers to understand the relationship between the type and nature of various problems and the available and accessible sources of assistance. Several choices had to be made in developing the decision tree model. It was necessary to restrict the number of alternative responses to each diagnostic question to only two (yes or no) in order to prevent the analysis from becoming impossibly complex. Another important question was the order in which the five basic input variables should be addressed. It seems most logical to begin with the question of business plans or ideas, as it is the basis for all other input variables. In so doing, one is in a better position to understand and calculate the trade offs associated with the other basic input variables (Orsere *et al.*, 2000).

The five basic questions generally call for one or more of the five assistance schemes shown in Figure 1. The first question (moving from left to right in the decision tree) addresses the great importance of clear business plans or ideas for efficient utilization of scarce resources. All the basic input variables place ones response on



**Figure 2.**  
A model of small business  
assistance

---

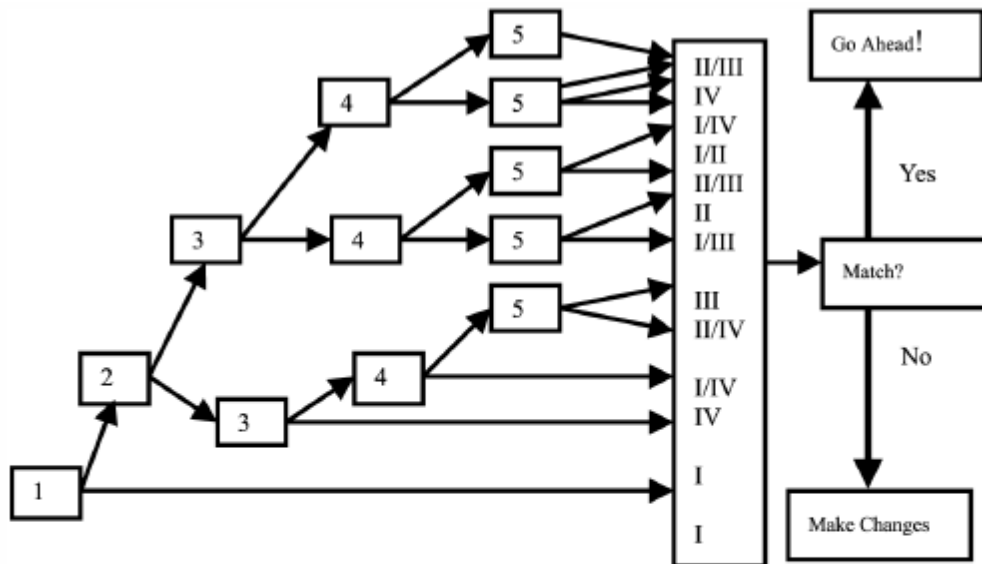

SS

**Keys:** 1-to-5 represents the five input variables in question form. I-to-IV represents the four recommended assistance schemes

either the advisory-resource continuum or the operational-strategic continuum of the typology of assistance schemes.

It is believed that one of the five cells (assistance schemes) will be more appropriate to some firms than others. One or more of the schemes will be more important to firms with positive response to questions 1 and 2, for example, and a positive response to question 1 and a negative response to question 2 or vice versa than any other scheme. The response to the five basic questions provides the ideal assistance scheme category as shown in Figure 2. Cell III (competitive awareness) followed by cell IV (total empowerment) is recommended to firms with sensible business ideas/plans, some previous exposure, owned by one person with own source of capital and operating in a service industry, because these two schemes focus on the development of strategic awareness and visionary leadership to achieve sustainable competitive advantages in the future. These firms are well-established and smoothly operating firms, whose active need is for assistance in meeting the challenges of competition and changes in the business environment.

The remaining part of the model is self-explanatory if one considers the basic dimensions and the various inputs. Policy makers and small business support agencies still need to refine each assistance scheme in view of the available resources and expertise. "What resources and capabilities do we have to effectively solve these business problems?" One's response to this question leads to a consideration of whether there is a match between resources and expertise one can comfortably and effectively use and the assistance scheme deemed most suitable for the present problem. Assuming that there is a match, one can proceed with the desired assistance scheme but with continual reassessment of the maturing situation, because of the developmental nature of the assistance process itself. This continual reassessment will help keep the policy maker in step with a dynamic situation. If there is not a match

between the selected scheme and the scheme one can use effectively, the decision choice for the assessor becomes one of: trying to gradually alter the situation or input variables; increasing the number of alternative schemes; or reconsidering whether to assist the firm at all (at this time). Thus, successful application of the model requires a significant amount of professional judgment on the part of the assessor.

However, this model is not intended as an instrument to be applied in the presence of prospective entrepreneur, but rather as a guide for structuring the dialogue between support providers/assessors and small firms. Ideally, the support provider will internalize the model, gather the data necessary for understanding the crucial problems of client firms, and determine the appropriate assistance scheme without the client knowledge that a model, per se, is being employed. The next section highlights the importance of the model by presenting a case study of small business assistance programmes in Botswana.

### **Operationalization of the model: a case study**

This section presents a case study of the various small business support programs in the Republic of Botswana as evidence of the need for an integrated model of assistance. The government of Botswana has put great efforts and resources to promote the development of small firms. The major governmental effort was started when the Botswana Entrepreneurial Development Unit (BEDU) was established in 1974 to provide local firms with financial and non-financial assistance. BEDU was followed by the introduction of the Local Preference Scheme in 1978, (now called "the Local Procurement Programme"), which reserves up to 30 percent of the government annual procurement for local firms. Currently, there are many financial and non-financial governmental and non-governmental organizations that are committed to the provision of assistance to start up and established firms. This case study is aimed at promoting the need for developing a meaningful assistance model by studying the nature of client firms and the assistance options available in the economy.

#### *Financial Assistance Policy (FAP)*

The FAP is a generous loan and non-repayable outright grant scheme formed in 1982 to provide financial assistance for all firms and non-repayable outright grants for medium and large firms (Ministry of Finance and Development Planning, 1995). A study by Lisenda (1997) indicated that approximately P159 million FAP disbursements to SME and large-scale enterprises were issued during the 1991-1995 planning period. It also noted that from 1994/1995 to 1996/1997, the FAP approved 2,770 projects in the country. Moreover, small-scale projects accounted for 92 percent of the 2,770 projects, with a share of 34 percent of total funds. The medium and large-scale projects received 66 percent of the funds and projected to create 33,000 jobs (Lisenda, 1997). In 1997 and 1998 a total of 2,712 projects were approved and provided with a total FAP grant of P128, 737,657.00. These projects were expected to increase total employment by 10,819 (DIA, 1998/1999). Although the FAP has initiated some indigenous investment, three FAP evaluations (1989, 1995 and 2001) indicated that its implementation was characterized by lack of coordination and systematic approach in the use of the policy.



#### *Citizen Entrepreneurial Development Agency (CEDA)*

Finally, the FAP was replaced by CEDA to redirect the objective of government financial assistance toward achieving sustainable enterprise development. CEDA's assistance is now offered in the form of a loan as opposed to outright grants. The establishment of this agency is the outcome of the recommendation of National Conference on Citizen Economic Empowerment and the fourth evaluation of FAP in 2001 (Ministry of Finance and Development Planning, 2001). Today, CEDA is the main credit and loan facility for SMEs in Botswana

#### *Micro credit scheme*

The Government of Botswana has also introduced a micro credit scheme to address the problems of access to finance by informal micro businesses. The scheme provides loans ranging from P500-P20,000 to citizens to engage in new business ventures or improve already existing business (Ministry of Finance and Development Planning, 2001). Loans are given at an interest rate of 15 percent per annum, and repayments to be made in a maximum period of 36 months. Loan approval and granting is subject to proven business ability to generating enough cash to timely honor the agreed loan installments. One among many prerequisites to qualify for the loan, the applicant's current total annual income should be less than P40,000, a condition deliberately set to ensure the scheme exclusively targets micro enterprises. To ensure full compliance to the set prerequisites and competent and professional administration of the fund, the National Development Bank was appointed as fund administrators. Micro enterprises get subsequent loans on full payment of the previous loan and only one loan can be obtained at a time. It is also noted that loans will be made available only when the project to be financed can demonstrate the ability to repay the loan (DIA, 1998/1999; Sathyamorti, 2002).

#### *Credit guarantee fund*

This fund will guarantee loans to citizen and citizen owned businesses from P10,000 to P250,000. Banks are encouraged to give loans to businesspersons. However, government guarantees up to 60 percent of the loan in case of default. This fund was established to encourage banks to extend more loans and credits to SMEs. Banks are required to use their own fund in assessing applicants and ensuring that only profitable projects are considered (DIA, 1998/1999; Sathyamorti, 2002).

#### *Botswana Development Corporation (BDC) Limited*

BDC was established in 1970 to identify investment opportunities in Botswana for exploitation by both local and foreign investors. The control over BDC is vested on the board of directors and managed by a managing director. BDC provides investment advice, loans, and share capital for citizens, plots and buildings to investors, and finances firms generating significant employment and viable export oriented firms (BDC, 1992).

#### *Tswelopele (PTY) Limited*

Tswelopele (PTY) Limited is a government agency (A BDC/NDB/FMO joint venture) established in 1984 to provide similar services like BDC but to small and medium enterprises in Botswana. BDC focuses on only large firms or investments. Tswelopele

provides long and short-term loans, bank loan guarantee, and equity-share capital as well as investment advice to SMEs (BDC, 1992).

#### *Commercial banks*

There are many commercial and specialized banks in Botswana. All the commercial Banks are foreign international banks including: Standard Chartered Bank of Botswana Ltd (incorporated in 1975); Barclays Bank of Botswana Ltd (incorporated in 1975); First National Bank of Botswana (incorporated in 1991); and Stanbick Bank of Botswana (incorporated in 1992). It is not uncommon that the working relationship between banks and SMEs is characterized by negative feeling.

A study by Sunny and Babikanyisa (1994) showed that about 34 percent of initial capital is sourced from FAP, and 37 percent from equity sources, 2 percent from formal institutions and Non-governmental organizations and only 1.5 percent of total investment in SMEs come from Commercial bank loans. Another survey by Lisenda (1997) found that about 60 percent of financing was from FAP and Equity, which were the predominant sources during the start-up phase. The study also confirmed that the contribution of commercial banks to start-up capital is negligible. Thus, commercial banks in Botswana have been subjected to a flood of criticism by the media and the public at large for being insensitive over the handling of SMEs cases, overcharging interest payments, and demanding high collateral or security. As Howcroft and Beckett (1993) noted "they are out of touch, insensitive and greedy". Only none out of 2,665 firms reported in 1994 getting some of their start up capital from commercial bank loans (Sunny and Babikanyisa, 1994). In 1992, the GIMINI study (Daniels and Fisseha, 1992), which surveyed 1,243 micro-enterprises, showed that finance was a major problem for 74 percent of the firms. Morewagae *et al.* (1995) also confirmed that 74 percent of the firms reported finance as a major problem. Lisenda (1997) also found that 26 percent of the firms indicated finance as the major obstacle to their development.

#### *Non-banking financial institutions*

There are also non-banking financial institutions that provide financing services to SMEs. The National Development Bank (NDB) formed in 1964 for the purpose of promoting economic development in Botswana through the evaluation of investment projects and the administration of financial assistance to SME under FAP, Micro credit Scheme, BEDU, and Citizen Contractors Fund (CCF). The Botswana Building Society (BBS) was established in 1977 for the purpose of receiving funds from members of the public as share values and savings account and advances this fund as short and long-term loans for investors. The Botswana savings bank was formed in 1982 with the objective of receiving deposits from the public and lending the same for economic development. The Botswana Insurance Holdings Ltd pools finance from the general and life insurance funds and invest in viable projects in the country. Shcaba Investment Trust Company (SIT) was incorporated in 1984 to attract public interest in equity investment in a diversified portfolio of equities of various companies. The Botswana Stock Exchange was established in 1994 to provide a regulated place to deal in capital funds, shares, bonds, etc of the country. Botswana International Financial Services Center (IFSC) was established in 1999 to create a financial center through which international communities could invest not only in Botswana but also in the nonbearing African states. IFSC is empowered to collect foreign investment and



re-invest it in viable projects. New starts up with viable and sound business plans are also assisted by the IFSC (Bonu and Pelealo, 2001).

#### *Botswana Confederation of Commerce, Industry and Manpower*

Botswana Confederation of Commerce, Industry and Manpower is a private non-profit organization registered under the Trade Unions and Employers Organization Act 1983. BOCCIM represents the interest of the private sector and is recognized by the Government. It also influences Government Policy affecting the private sector through its representation on various advisory bodies (Brisco, 1995). BOCCIM sponsors training programmes, provides scholarships, offers industrial relations assistance, provides management counseling to member firms, especially to small business enterprises, promotes women owned businesses and communicates with member firms through newsletters, business luncheons, workshops, annual dinners and personal visits by the staff. The training courses designed for its members include Customer Service public; Industrial Disputes, Professional Selling Skills; Taxation; Finance for non-financial Managers; Communication Skills and the like (Bonu and Pelealo, 2001; Lisenda, 1997).

#### *Enterprise Botswana*

Enterprise Botswana is an entrepreneurship institution to promote and support the creation, growth and expansion of small and medium enterprises. It is a tripartite initiative support by the Government of Botswana, The United Nations Development Programme and private sector enterprises comprising Debswana Diamond Company, Shell Oil Botswana, Kgalagadi Management Services, Garona Investments and Botswana Furniture Manufacturers. The main focus of Enterprise Botswana is to support and advance the development of entrepreneurship through skills enhancement in the form of training and extension services (Lisenda, 1997).

#### *Small Business Clinic*

The AIESEC Botswana under the Community Assistance Programme set up a Small Business Clinic in 1995. The clinic aims to assist small-scale enterprises with a view to uplifting their level of operation. The overall objective of the clinic is: to promote interaction between students of University of Botswana and small business community; to empower small business owners with modern business principles; and to give students of University of Botswana practical experience in the operation of small businesses in Botswana. The Small Business Clinic also assist small business entrepreneurs who wish to seek financial assistance but are unable to afford the high fees charged by consultants for the preparation of acceptable financial reports. The clinic also assists in the area of project planning by carrying out feasibility studies. The clinic serves as an information center for small, medium and large-scale enterprises in the country. Finally, the clinic also assists those enterprises that BOCCIM and consultancy firms cannot help because of lack of resources. The clinic also organize periodic training, seminars and workshops for members, clients, and co-ordinate the presentations on small business problems by resource people. Members are provided with in-house training in areas including: how to construct a business plan; how to fill up FAP application forms; computer training in data base and other areas; loan applications for business; and company registration procedures (Sathyamorti, 2002).



### *The Department of Industrial Affairs (DIA)*

The DIA is charged with the responsibility of promoting the development of industry and the transfer of industrial technology through a variety of public policy instruments with the aim of diversifying the economy, increasing employment opportunities, developing local entrepreneurship and increasing the participation of Botswana at all levels of industry (DIA, 1996/1997). Its Integrated Field Services (IFS) division is responsible for the design and conduct of the training programmes for the small business entrepreneurs. This is the largest division within the DIA and constitutes more than three quarters of the total establishment of the department. It consists of the Business Management Development Services (BMDS), the Industrial Technology Support Services Section (ITSS) and the IFS Field Stations. The division has been set up primarily to support the development of small-scale indigenous enterprises through the provision of training to various target groups at different levels in the area of business management, metalwork, pottery, construction management, garment manufacture, carpentry and leatherworks and other technical training. The aim of the training programme is essentially to enable the small business entrepreneurs to improve their organizational performance (DIA, 1995/1996, 1997/1998; 1998/1999).

### **Discussions, conclusions and implications**

Despite the efforts made by a number of small business assistance programs in Botswana, the pace of development of entrepreneurship and small business is far from satisfactory. This could be attributed, among other things, to the lack of coordination in the implementation of support programmes. The purpose of this paper is to show some evidences of the need for a small business assistance model that integrates the current fragmented approach in supporting the development of small firms.

Since the model is not field-tested, its application should be limited to the provision of conceptual framework in understanding the relationship between small business problems and assistance schemes. The model is designed to assist not to replace the informed judgment of the assessor or support provider. For example, whether or not entrepreneurs have previous business experience to successfully run the new business has to be the decision of the assessor, not the entrepreneur. Since the information necessary to make determination may require numerous questions, the assessor may need to move through the two continuums a number of times as more data become available with respect firm characteristics.

The model is not a panacea for all small business problems. It is offered as one possible guide for systematically considering the contingencies critical to the designing of small business assistance programmes and policies that are needed to enhance the promotion of small business development. Thoughtfully applied by experienced professional assessors, the model can help policy makers and small business support groups to provide better assistance and advice to inexperienced entrepreneurs, thereby increasing their chances for business success.

### *Implications for policy makers*

The future success of small business support programs as a development tool will depend heavily on public-private partnership to develop a diverse but integrated set of programmes and institutions to meet the different needs of small firms. The design of such programmes must be based on a thorough understanding of the causes of their

failures, as well as the specific reasons for the lack of coordination among the various programmes in the economy. Important implications for public policy makers pertain to the need for feasibility study for integrating the various assistance programmes. Would potential entrepreneurs need a variety of financial and non-financial support programmes to improve their performance? What are the major obstacles faced by existing support programmes in their attempt to provide meaningful assistance? To what extent are these obstacles related to the lack of coordination among business support programmes carried out by public, private and non-profit organizations? To what extent would small firms be dependent on the support programmes? A focus on such questions must be emphasized in feasibility studies before the design for small business assistance is drawn up.

Another important policy implication is about the debate on cost-benefit analysis. Small business support programmes should not be designed without considering their opportunity costs. As most programmes are still subsidy dependent, a pula (Botswana currency) spent on supporting small firms means a pula less for another potential development intervention.

Policy makers can learn several possibilities from the decision tree model, which encourages a holistic approach in handling small business problems. Support programmes in Botswana have not been effectively used to assist small firms due to fragmentation and duplication. They are mostly carried out independent of each other and are not complementary. A small business with chronic shortage of working capital can, for example, approach banks (private sector), or Citizen Entrepreneurial Development Agency (public sector) or Micro Finance House (non-profit organization), for short-term loans, and integrated field services (public sector) or The Botswana Confederation of Commerce, Industry and Manpower (private sector) or The Small Business Clinic (non-profit organization) for training and technical assistance. Hence, public-private partnership in designing an integrated support programmes will provide better and meaningful assistance to small firms.

If there is an integrated model of small business assistance, actual problems can be carefully studied and appropriate assistance could be provided not only to solve short-term operational problems but also to achieve sustainable development through continued assistance. Thus, the proposed conceptual model can serve policies makers as a foundation for integrating the various assistance programmes in the economy.

Another policy implication of the model pertains to the debate on the compatibility of public, private and nonprofit assistance programmes, whose primary objectives are different and sometimes conflicting. For instance, the primary objective of banks and governmental organizations in extending loan for small firms are not similar. The challenge for public policy makers is therefore to find ways of coordinating the efforts all parties involved in the promotion of small firms.

#### *Implications for further research*

The conceptual model has not been field-tested and validated. Thus, further research is needed to collect empirical data to test and validate the model. Moreover, very little systematic study has been done to design an integrated model of small business assistance and to measure the external efficiency of existing support programmes. This could be attributed largely to the difficulty in quantifying and comparing the benefits and costs of program interventions. Thus, further research is needed to



examine what organizational and management frameworks are most conducive for public-private partnership in assisting small firms as well as what institutional arrangements and governance structures are needed to achieve support compatibility among donors, stakeholder, government agencies, program managers and clients.

Moreover, further research is needed to measure the effectiveness of existing business support programs (separately and collectively) in terms of their impact on entrepreneurial attitude, perceptions, understanding, and behavior, and on business outcomes. This could be effectively accomplished through longitudinal rather than cross-sectional studies of support recipient firms. Designers of support programs should study the successful experience of similar programs in developed economies like the USA and decide which of these experiences can be applied in the developing country under consideration.

#### *Implications for management practitioners*

Management practitioners need to clearly understand the cost-benefit relationship while seeking external assistance. There is a general misperception of government assistance in Botswana. Several firms perceive that financial and other assistance provided by the government are non-repayable and many firms show no commitment to repay government loans without legal enforcement. As a result managers tend to continue using government assistance rather than approaching banks and other venture financing firms to solve their problems. Another implication for practitioners relates to the timing for external assistance. Although there are plethora assistance programmes in the economy, they become successful only when they are used at the right time for the right purposes. The proposed model assumes that small firms seek external assistance after exhausting all other possible sources. Management practitioners are therefore responsible to find alternative strategies to overcome their problems, and it is only after these alternatives are exhausted that they should seek external assistance.

#### **References**

- Argenti, J. (1976), *Corporate Collapse: The Causes and Symptoms*, McGraw-Hill, London.
- Asri, A.M. and Baker, M.I. (2000), *Small and Medium Enterprises in Asian Pacific Countries*, Science Publishers, Inc., Huntington, NY.
- Barton, S.L. and Mathews, C.H. (1989), "Small firm financing: implications from the strategic management perspective", *Journal of Small Business Management*, Vol. 27 No. 1, pp. 1-8.
- Bhatt, N. and Shi-Yan, T. (2001), "Delivering microfinance in developing countries: controversies and policy perspectives", *Policy Studies Journal*, Vol. 29 No. 2, pp. 24-39.
- Bonu, S. and Pelealo, P. (2001), "Financial institutions as facilitators of economic growth: a case study of Botswana", *The African Journal of Finance and Management*, Vol. 10 No. 1, pp. 8-22.
- Botswana Development Corporation (BDC) (1992), Annual Report.
- Brisco, A. (1995), *The Promotion of Small and Medium Enterprises in Southern Africa*, Southern African Development Community (SADC), Gaborone.
- Cowan, D.A. (1990), "Developing a classification structure of organizational problems, an empirical investigation", *Academy of Management Journal*, Vol. 33 No. 2, pp. 366-90.
- Daniels, L. and Fisseha, Y. (1992), *Micro and Small-scale Enterprises in Botswana: Results of a Nation-wide Study*, Gemini Technical Report, Ministry of Finance and Development Planning, Gaborone.



- Department of Industrial Affairs (DIA) (1990/1991), Annual Report, Government Printers, Gaborone.
- Department of Industrial Affairs (DIA) (1995/1996), Annual Report, Government Printers, Gaborone.
- Department of Industrial Affairs (DIA) (1996/1997), Annual Report, Government Printers, Gaborone.
- Department of Industrial Affairs (DIA) (1997/1998), Annual Report, Government Printers, Gaborone.
- Department of Industrial Affairs (DIA) (1998/1999), Annual Report, Government Printers, Gaborone.
- Government of Botswana (1997), *National Development Plan (NDP) 8, 1998-2003*, Government Printer, Gaborone.
- Government of Botswana (1998), *Small, Medium, and Micro-Enterprise Task Force Report*, Government Printers, Gaborone.
- Howcroft, B. and Beckett, A. (1993), "Changes in UK bank branch networks: a customer perspective", *The Service Industries Journal*, Vol. 13 No. 4, pp. 267-88.
- Lisenda, L. (1997), "Small and medium scale enterprises in Botswana: their characteristics, sources of finance and problems", BIDPA working paper, no. 14, pp. 1-26.
- Ministry of Finance and Development Planning (1995), *Financial Assistance Policy (FAP)*, 3rd revision report, Government Printers, Gaborone.
- Ministry of Finance and Development Planning (2001), *CEDA Guideline*, Government Printers, Gaborone.
- Modigliani, F. and Miller, M.H. (1958), "The cost of capital, corporation finance and the theory of investment", *American Economic Review*, Vol. 48, pp. 261-96.
- Morewagae, B.S., Monica, S. and Henry, R. (1995), "Access to credit for non-formal micro-enterprises in Botswana", *Journal of Development Studies*, Vol. 31 No. 3, pp. 21-32.
- Olen, L.G. (1989), "A decision tree approach to the design and implementation of accounting and information systems for small businesses", *Journal of Small Business Management*, January, pp. 8-16.
- Orsere, B.J., Sandy, H. and Riding, A.L. (2000), "Performance, firm size, and management problem solving", *Journal of Small Business Management*, Vol. 38 No. 4, pp. 42-59.
- Randolph, W.A. and Barry, P. (1979), "Designing meaningful learning situations in management: a contingency, decision tree approach", *Academy of Management Review*, Vol. 4 No. 3, pp. 459-67.
- Sathyamorti, R. (2002), "Financial and non-financial institutions and small business development: Botswana experience", paper presented at the International Conference on African Entrepreneurship and Small Business Development, September 19-20, White Sands Hotel, Dar Es Salaam.
- Sunny, G. and Babikanyisa, V. (1994), "The second best: the role and constraints of the non-formal sector in Botswana", unpublished paper, University of Botswana, Gaborone.
- Temtime, Z.T., Chinyoka, S.V. and Shunda, J.P.W. (2002a), "A decision tree approach for designing meaningful small business assistance schemes: a conceptual model", paper presented at the SAIMS Conference, Sun City, October 30-November 1.
- Temtime, Z.T., Shunda, J.P.W. and Chinyoka, S.V. (2002b), "Toward entrepreneurial marriage between business incubators and start ups", paper presented at the 12th Intent Global Conference, Johor Baharu, July 8-11.
- Theodore, J.M. (1972), "A decision tree approach to the methodological decision process", *The Accounting Review*, Vol. 1 No. 1, pp. 826-9.
- Williams, M.L. (1993), "Measuring business starts, success and survival, some database consideration", *Journal of Business Venturing*, Vol. 8 No. 4, pp. 295-9.