

THEORETICAL ANALYSIS OF AN OFFSET SINGLE-STROKE RAM PRESS FOR SUNFLOWER OIL EXTRACTION

Ivan A. LOUKANOV, Jacek UZIĄK

University of Botswana, Dept. of Mechanical Engineering, P/Bag UB0061, Gaborone, Botswana

Abstract: The single-stroke ram press machine is widely used for sunflower oil extraction in African countries. It is manually operated, low speed machine constructed on the basis of slider-crank mechanism. The paper presents a detailed theoretical analysis of the mechanics of the linkage system. The analysis is done for different positions of the driving lever (handle) and other parameters, which influence the performance of the machine. Based on that analysis conclusions on the optimal performance of the mechanism are drawn.

Keywords: ram press, slider-crank mechanism, static analysis

1. Introduction

The single-stroke ram press machine is widely used for sunflower oil extraction in African countries. It is manually operated, low speed machine designed on the basis of slider-crank mechanism. The press consists of a ram (long piston) of relatively small diameter that presses a measured amount of oil-seeds into a metal cage, where due to a high pressure developed, the process of expression of oil from the seeds takes place. The machine in this form was originally invented and designed by C. Bielenberg in 1986 and is still successfully used in practice. A simplified model of this machine was proposed and analysed by Henrikson [2, 4]. The model includes the driving lever with the upper and lower pin, but neglects the piston-cylinder pair and the endpin joint. However, a consistent and profound analysis of this machine has never been done. There are several possibilities of improving the performance of the ram press machine, and these are: proposing a new kinematic configuration of the mechanism, varying the existing linkage proportions or by introducing an offset in the slider-crank mechanism. In this paper the latter option is discussed in combination with the variation of the linkage proportions.

2. Geometry of the machine

The machine, as mentioned above is a modified slider-crank mechanism having a projected crank in the form of a lever. The introduced offset in the slider-crank mechanism can be seen in Fig. 1, where 1 - is the lever (crank), 2 - is the connecting rod, 3 - is the piston (ram) and D , B and E are the main (lower) pin, upper and end pin joints respectively. The geometry of the mechanism is clearly described by the following parameters: a - the length of the lever, b - the length of the crank, c - the length of the connecting rod, and e - the introduced offset. The value of the offset can be either positive or negative, depending whether the piston moves above or below the main pin D .

A particular position of the mechanism is described by the position angle (of the lever) α , which fully specifies the positions of the rest of the linkages as well as angles β and γ . The relationship between the angles can be written as follows:

$$\gamma = \alpha - \beta \quad (1)$$

$$\sin \beta = \frac{b \sin \alpha - e}{c} \quad (2)$$

Vectors \vec{E} and \vec{R} (Fig. 1) are the external forces acting on the system, where \vec{E} is the effort applied to the handle by the operator and \vec{R} is the resistant force acting on the piston face due to the pressure developed in the cage.

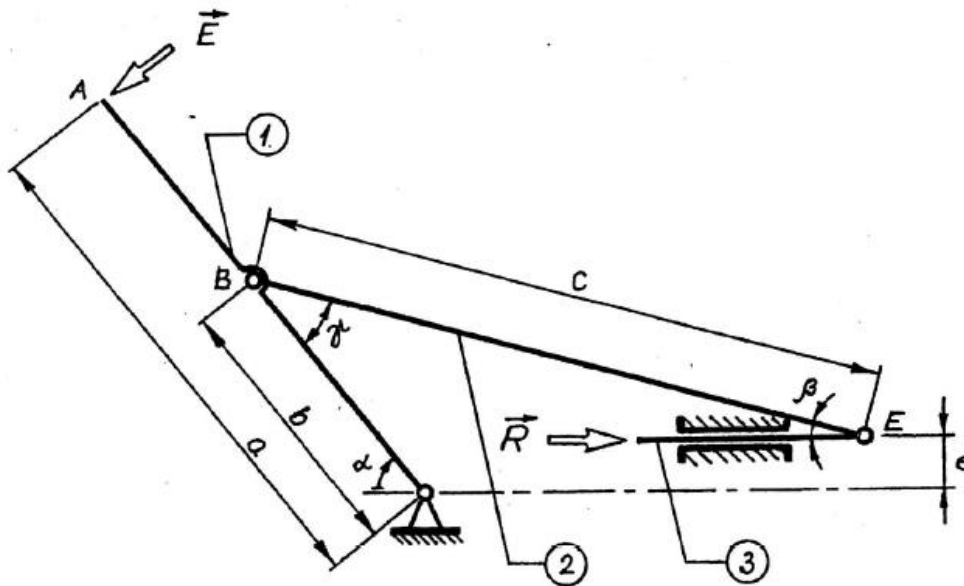

Fig. 1 Geometry of the ram-press mechanism

The free-body-diagrams for the individual members of the mechanism are shown in Fig. 2. In this analysis friction is considered not only in the pin joints, but also in the piston-cylinder pair. In the rotational pairs friction is introduced in the form of friction torques and friction forces, while in the piston-cylinder pair it is represented by different friction forces. Also additional friction force (\vec{F}) is introduced on the piston due to the rubbing effect between the labyrinth cake seals and the cylinder.

3. Static analysis

As it was stated before the ram press is a manually operated low speed machine and therefore there is no need for dynamic analysis. The inertia forces, due to low speed variation are negligibly small and hence the static analysis will be sufficient for the purpose of this investigation.

Based on the free-body-diagrams shown in Fig. 2 the force analysis of the mechanism was conducted in order to calculate the necessary forces and later to form ratios between some of these forces. The equations of static equilibrium were derived for the main components of the machine, such as the lever and piston.

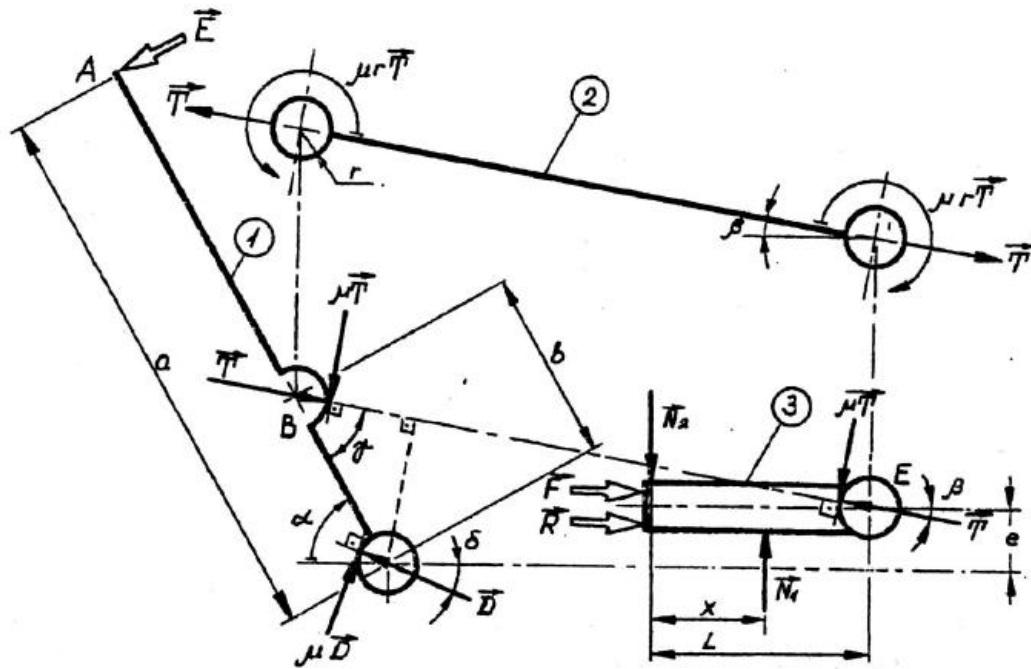

Fig. 2 Free Body Diagrams for the major elements of the ram press mechanism

In Fig. 2, the friction torques were introduced to make the drawing more readable but the equations were derived for the actual friction forces acting at each pair. The friction forces are assumed to be perpendicular to the radii of the respective bushes at their points of application and acting at a distance equal to the radius of the bush. All radii of the bushes (pins) in this machine were of the same size. The well-known expression for the friction force formed by the product of the coefficient of dry friction (μ) and the normal force is employed.

With the assumptions mentioned above, the equations governing the equilibrium for the lever ABD are:

$$-E \sin \alpha + T \cos \beta - \mu T \sin \beta - D \cos \delta + \mu D \sin \delta = 0, \quad (3)$$

$$-E \cos \alpha - T \sin \beta - \mu T \cos \beta + D \sin \delta + \mu D \cos \delta = 0, \quad (4)$$

$$Ea - Tb \sin \gamma + T\mu(\sin \gamma - r) - \mu Dr = 0. \quad (5)$$

Where α , β , γ are the angles as presented in Fig. 1 and Fig. 2; and T , E , and D are forces as presented in Fig. 2; r is the radius of the bush (pin), and μ is coefficient of dry friction in the kinematical pairs.

Similarly, the equations of static equilibrium for the piston were written as follows:

$$R + \mu(N_1 + N_2) - T(\mu \sin \beta + \cos \beta) = 0, \quad (6)$$

$$N_1 - N_2 + T(\sin \beta - \mu \cos \beta) = 0, \quad (7)$$

$$-N_1(l - x) + N_2 l + \mu \frac{d}{2}(N_1 - N_2) + \mu Tr = 0. \quad (8)$$

Where N_1 and N_2 are the normal reactions acting on the piston, d is the diameter of the piston, l is the maximum distance between the piston's face and centre of the pin E , and x is the actual distance between the normal reactions N_1 and N_2 . Because of the variable piston's length being in contact with the cylinder, and also to account for the existing clearance between the piston and the cylinder, the normal forces N_1 and N_2 mentioned above were introduced. They are applied at the beginning of the piston and at the final

point of contact between the piston and cylinder respectively. The position of force N_1 is specified by the variable distance x , which is dependant upon the motion of the mechanism.

The above equations are the necessary basis for further force analysis of the ram press mechanism. Using these equations the ratios between the effort (E) and the other forces such as T and R were introduced as well as some dimensionless geometrical ratio. These values were used in calculating the mechanical advantage, velocity ratio, efficiency and the transmission angle of this mechanism [2, 3, 5].

4. Calculations

The calculations involved in the present study are not much complicated but it is impossible to present the analytical solutions in a short form. The calculations were done on a spreadsheet, which not only allows for a repetition of the calculations for different angles of the handle position (α) but also to change some of the ratios used.

In order to find the influence of the offset on the performance of the machine, the calculations were performed for different ratios between the offset (e) and the crank length (b). The lengths of the lever (a), the crank (b) and connecting rod (c) were assumed to be as for the real machine CAPU-BP 42 manufactured by RAM Ltd., Zimbabwe. These were measured and found to be: $a = 1.71$ m, $b = 0.08$ m, and $c = 0.653$ m. The calculations were accomplished by varying the lever's position angle (α) from 70° to 0° as it is in a real situation, when the machine is in use.

5. Results and Discussion

The results obtained from the calculations are presented in Figs. 3-6. They are valid for the value of the coefficient of dry friction $\mu = 0.3$ but similar graphs were found for other values of the same coefficient.

The preliminary calculations revealed that negative offset (which physically means that the piston and cylinder are arranged below the main pin D) resulted in negative values (not shown in these graphs) of the velocity ratio and the efficiency for a certain range of angle α . This is probably due to the fact that for larger values of the negative offset, from certain value of angle α , the piston began to move in the opposite direction, and hence pressure dropped suddenly to zero and thereafter it became negative. This phenomenon was found for the offset ratio e/b below -0.5 , and therefore omitted from the above graphs.

In this paper all the graphs shown in the above figures were plotted for four different values of the offset ratio e/b , namely, -0.5 , 0 , $+0.5$, and $+1.5$. It should be noted that the value of the offset ratio $e/b = 0$ corresponds to the original design of the ram press machine without an offset.

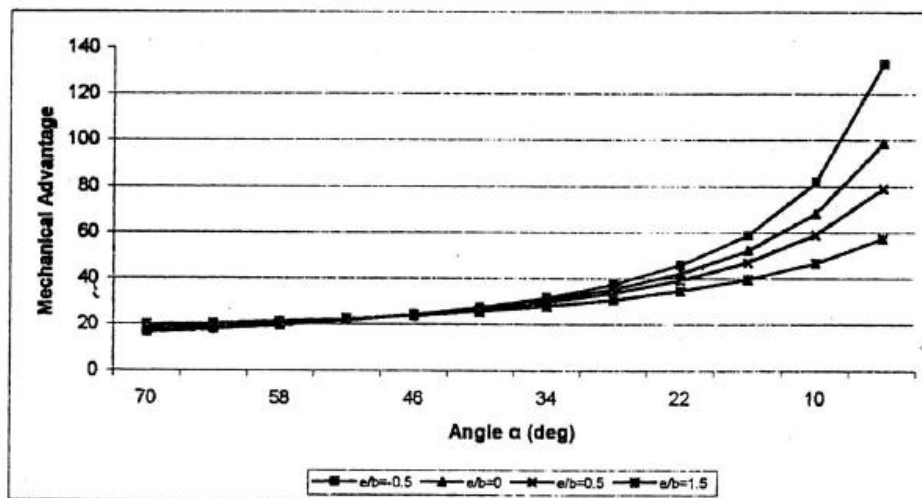

Fig. 3 Mechanical Advantage vs. lever angle

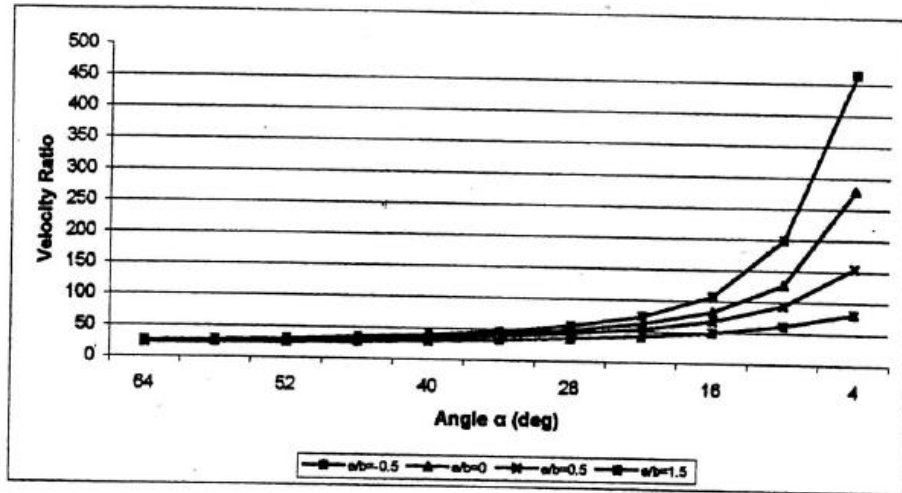

Fig. 4 Velocity Ratio vs. lever angle

From Fig. 3 it can be seen that the mechanical advantage does not change dramatically with the introduction of the offset for the angle α ranging from 70° to 30° . But for smaller values of angle α mechanical advantage changes significantly. However, it can be noticed that the mechanical advantage has the highest values for the negative offset and is reduced when the offset is increased (from negative value through zero to positive values).

Fig. 4 shows the same trend of influence upon the velocity ratio as that in the mechanical advantage but the effect is more pronounced for the smaller values of angle α .

As far as the efficiency is concerned (Fig. 5) the offset has a reverse effect and the efficiency increases with the higher values of the offset from negative to positive. It is also seen that the efficiency is almost steady for a great variation of angle α (from 70° to 30°), but it depreciates quickly for the range 30° to 0° .

Fig. 6 shows that the transmission angle has very high values for all offsets considered. All the values of the transmission angle are above 80° , and according to Erdman [1] and Martin [3] indicates good performance of the machine. Close inspection of these graphs reveals that for a positive offset the transmission angle is higher than for zero offset although it is not valid for the whole range of angle α .

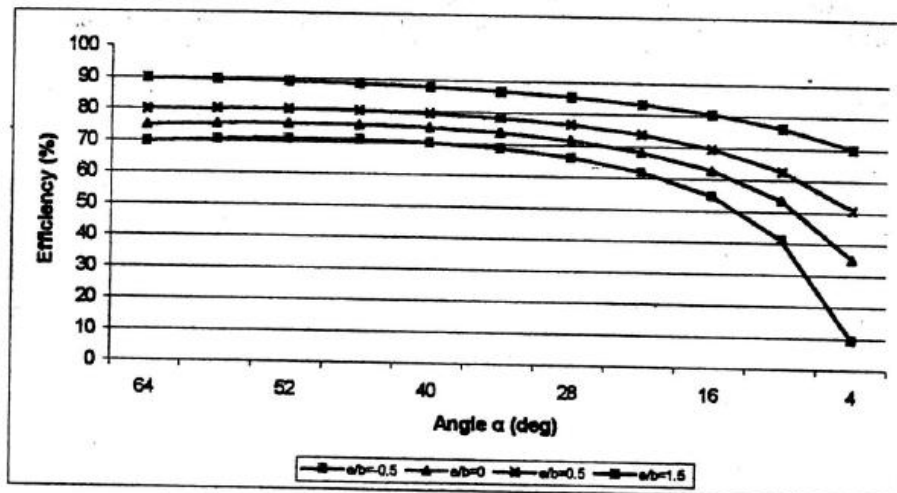

Fig. 5 Efficiency vs. lever angle

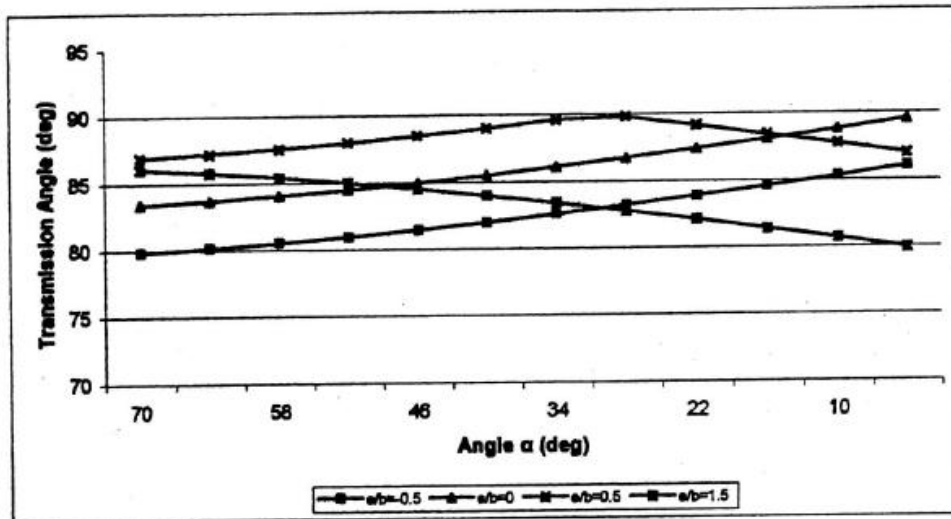

Fig. 6 Transmission Angle vs. lever angle

6. Conclusions and Recommendations

Based on the above analysis and results obtained it is obvious that the offset (e/b) introduced has an increasing influence upon efficiency. For smaller values of α ($0^\circ \leq \alpha \leq 30^\circ$) the effect of offset upon mechanical advantage and velocity ratio becomes quite significant. It can be also seen that efficiency increases with positive values of the offset (Fig.3). Increased values of the offset also lead to an increased values of the transmission angle, up to some limited values of the position angle α . It is recommended that the positive offset of the value less than 0.5 should be introduced in order to improve the performance of the press.

References:

- [1] Erdman, A.G., Sandor, G.N., "Mechanism Design: Analysis and Synthesis", Prentice Hall, 1991.
- [2] Henriksson, B., Calculation of the Mechanical Advantage in a Ram Press including Friction. AGRITEX, Borrowdale, Harare, Zimbabwe, 1994.
- [3] Martin, G.H., "Kinematics and Dynamics of Machines", McGraw-Hill, 1982.
- [4] Nazare, R., Henriksson B., Ngere R., The Ram Press System. A final research report from the project "Rural Small Scale Oil Expression in Zimbabwe", AGRITEX, Borrowdale, Harare, Zimbabwe, 1994.
- [5] Norton, R.L., "Design of Machinery", WCB McGraw-Hill, 1999.